

Bird on a Branch

Finished quilt size: 20" x 54"



Bird on a Branch made by Linda Jenkins, 2008

Here's an idea! Linda made this cute wall quilt using just the left side border from *Tree O' Life* (page 34). There are an infinite number of ways to use the many design elements in this book.

Materials

Refer to our book *The New Appliqué Sampler* and our DVD *Learn to Appliqué the Piece O' Cake Way!* for more complete descriptions of our appliqué techniques.

This is a scrappy quilt. Use the yardage amounts as a guide, as they will vary with the number of fabrics you use.

Orange block background: A variety of fabrics to total 1 yard

Appliqué: A variety of large scraps of fabric

Orange print border: ½ yard

Maroon inner border: ¼ yard

Binding: ¾ yard

Backing and sleeve: 1½ yard

Batting: 26" × 62"

Cutting

When cutting without your ruler, you will guesstimate the sizes listed in the project. You can refer to the grid lines on your mat or on a ruler placed nearby—*just don't use the ruler*. If you cut too large a piece, you can trim it later. If you cut too small a piece, you can add to it to bring it up to size (refer to Preparing the Backgrounds for Appliqué on pages 46–47 and Coping Strips on page 47). If you are using a ruler, cut the specific sizes shown here.

Orange block background fabrics

Construct 1 rectangle approximately 14" × 52" from a variety of orange fabrics **OR** measure and cut 1 rectangle 14" × 52".

Appliqué fabrics

Cut fabric as needed (refer to Block Assembly below).

Orange print border fabric

Cut 4 strips approximately (or exactly if you are using a ruler) 3½" × 40".

Maroon inner border fabric

Cut 4 strips approximately (or exactly if you are using a ruler) 1¼" × 40".

Binding

Cut 1 square 22" × 22" to make a 2½"-wide continuous bias strip 180" long (refer to page 49).

Block Assembly

Refer to pages 52–58 for instructions on making the templates, making the positioning overlay, and preparing the appliqué. Appliqué patterns are on the pullout at the back of the book.

1. Use the pattern for the left side border from *Tree O' Life* to make templates and overlays for the block. Enlarge the patterns as instructed on page 53.
2. If you haven't prepared or pieced your background, do so now (refer to Preparing the Backgrounds for Appliqué on pages 46–47).
3. Press the block background in half horizontally and vertically. Place the background on your design wall.
4. Trace around the appliqué shapes onto the appliqué fabrics (refer to Using Templates Loosely on page 54). Cut out the appliqué pieces for each block, including a ¼" turn-under allowance. Use the overlay as you choose (refer to Using Positioning Overlays Loosely on page 57), and place the appliqué pieces on the backgrounds on your design wall. Play with your color/fabric choices until you are happy with the way your quilt looks.

Audition the Entire Quilt

It's a good idea to get the entire quilt, including the sashing strips, on your design wall *before* you begin any stitching.

5. Appliqué the block. Finger-press the edges as you go. When your appliqué is complete, press the block on the wrong side.

6. Trim the block to approximately (or exactly if you are using a ruler) $12\frac{1}{2}'' \times 50\frac{1}{2}''$.

Border Assembly

1. Sew together the inner border strips end-to-end. Cut approximately (or exactly if you are using a ruler):

2 strips $1\frac{1}{4}'' \times 50\frac{1}{2}''$ for the side borders

2 strips $1\frac{1}{4}'' \times 14''$ for the top and bottom borders

2. Sew together the border strips end-to-end. Cut approximately (or exactly if you are using a ruler):

2 strips $3\frac{1}{2}'' \times 52''$ for the side borders

2 strips $3\frac{1}{2}'' \times 20''$ for the top and bottom borders

Quilt Assembly

Refer to the Quilt Assembly Diagram and Putting Together the Quilt (page 47).

1. Sew the side inner borders to the quilt. Trim or add to the inner border strips as necessary. Press the seams toward the inner border.

2. Sew the top and bottom inner borders to the quilt. Trim or add to the inner border strips as necessary. Press the seams toward the inner border.

3. Sew the side borders to the quilt. Trim or add to the border strips as necessary. Press the seams toward the border.

4. Sew the top and bottom borders to the quilt. Trim or add to the border strips as necessary. Press the seams toward the border.

5. Layer and baste the quilt. Quilt by hand or machine (refer to page 48).

6. Finish the quilt (refer to page 48).

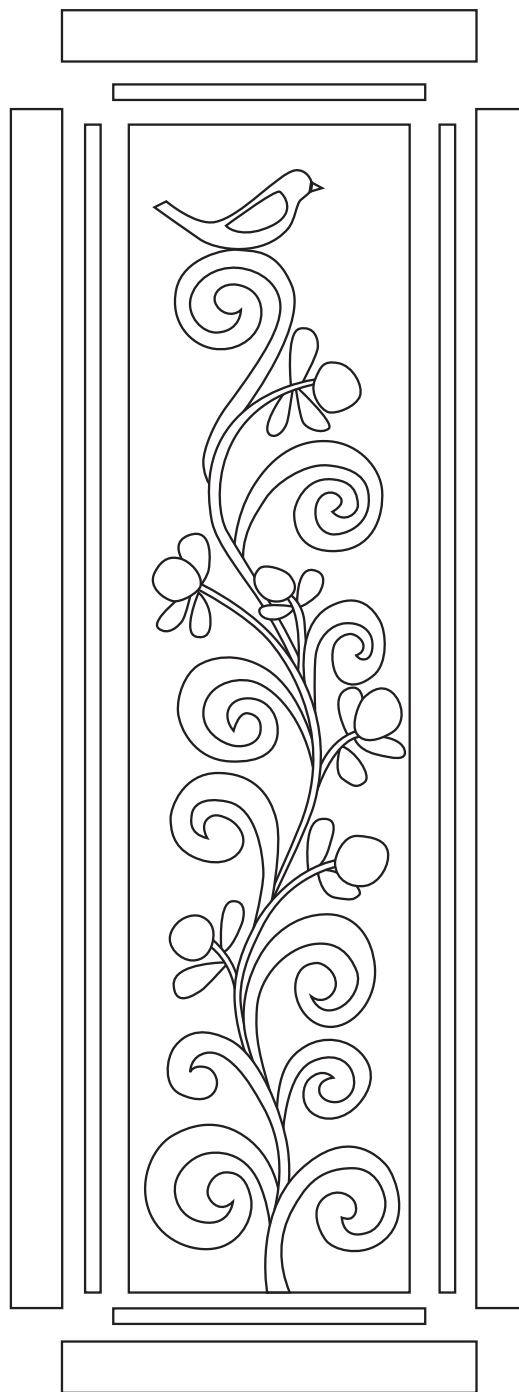

Quilt Assembly Diagram

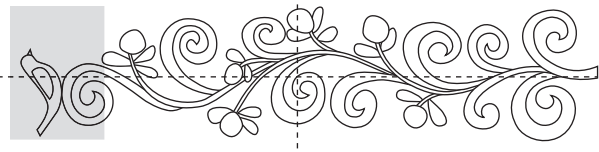

Tree O' Life Left Side

To make complete pattern, join the following pages, following the diagram for reference.

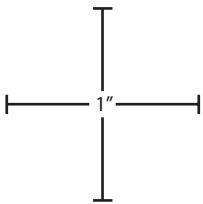
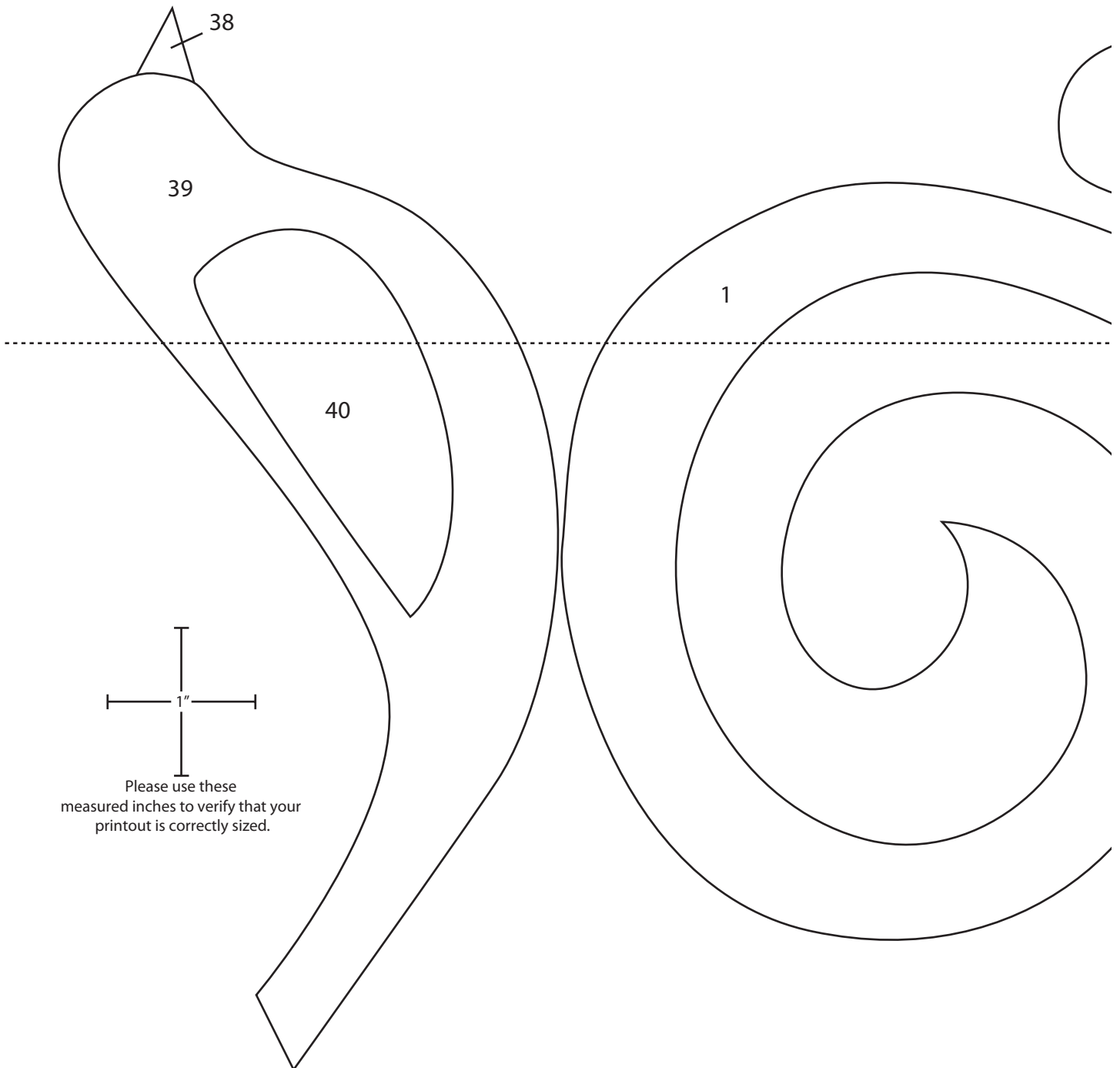

Please use these measured inches to verify that your printout is correctly sized.

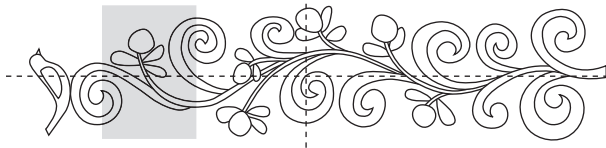
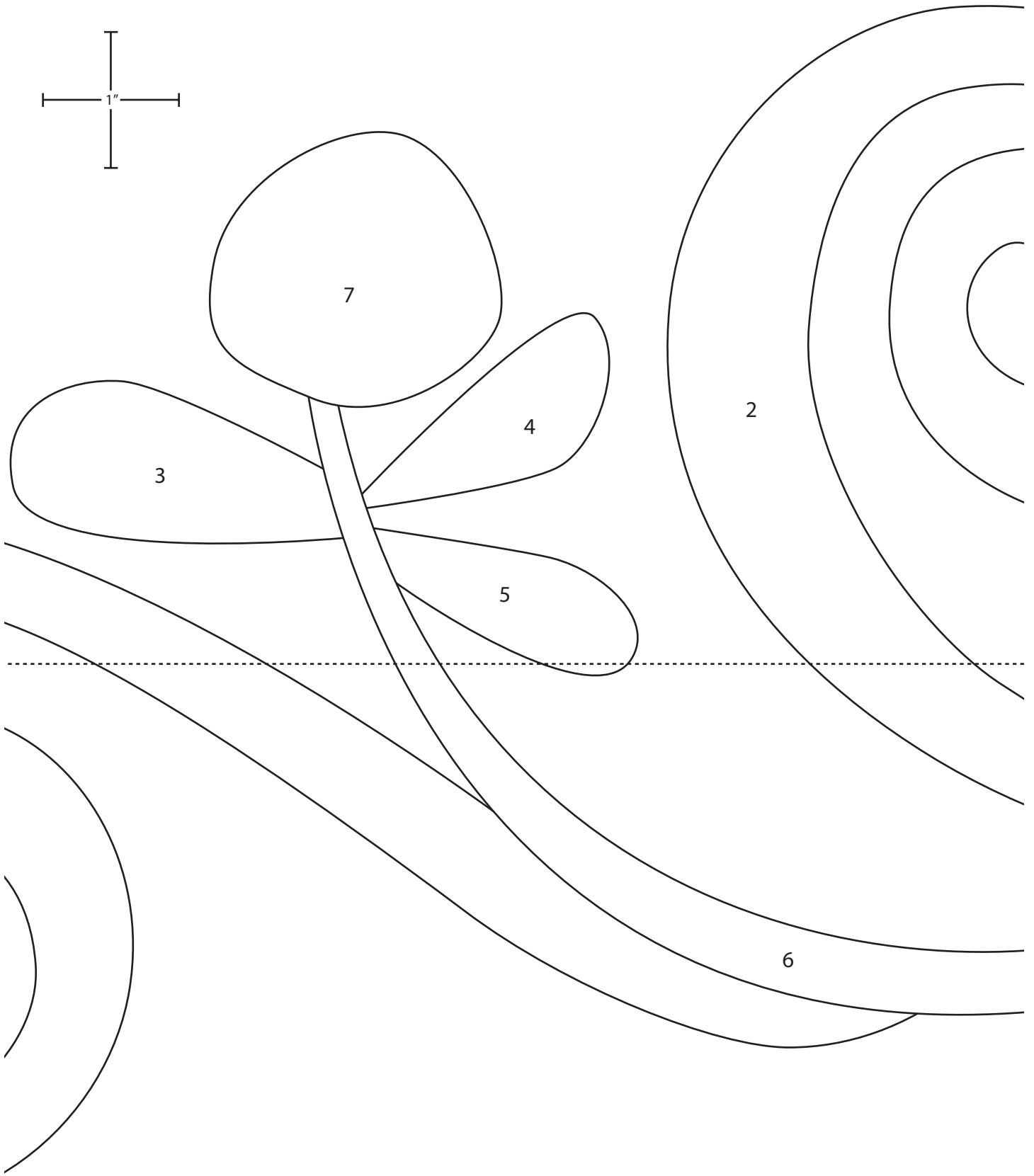
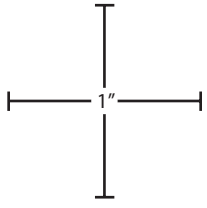

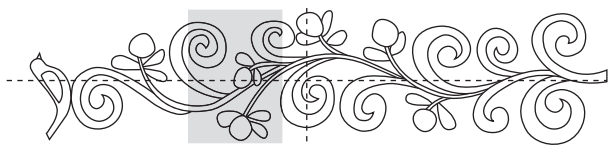
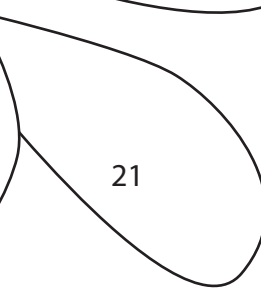
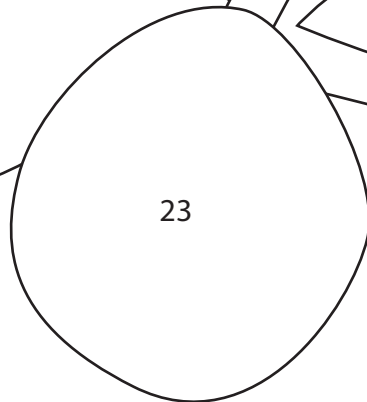
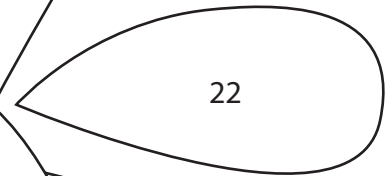
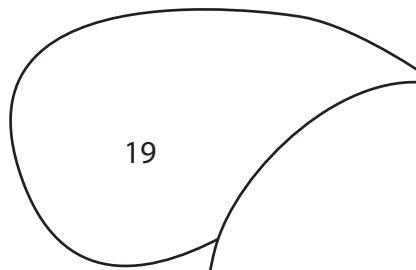
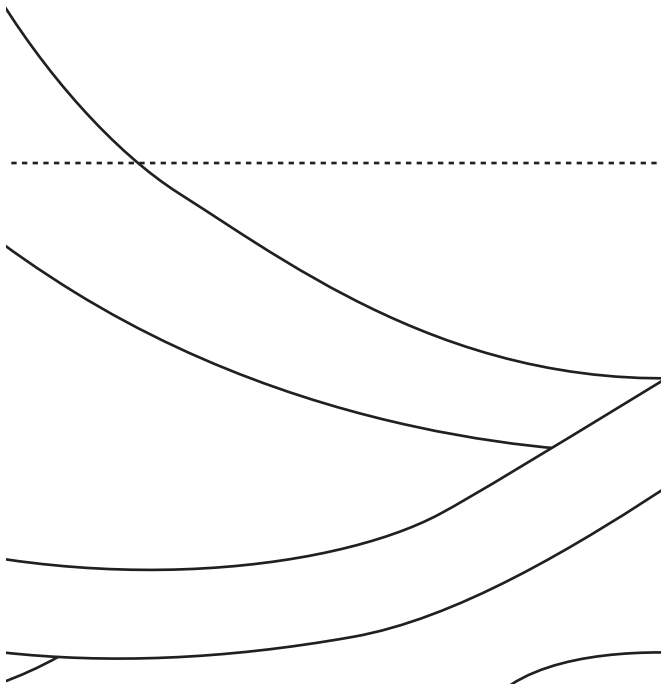
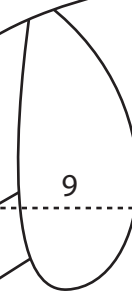
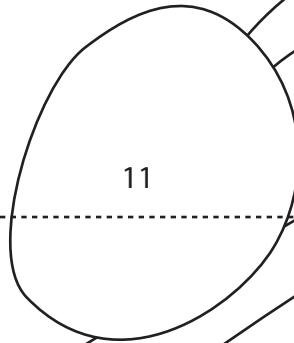
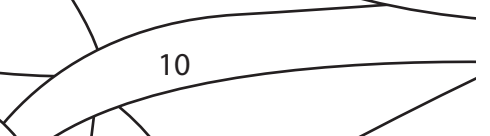
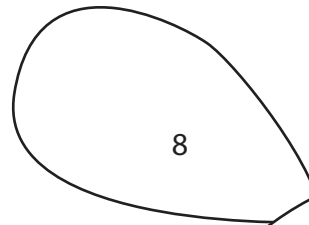
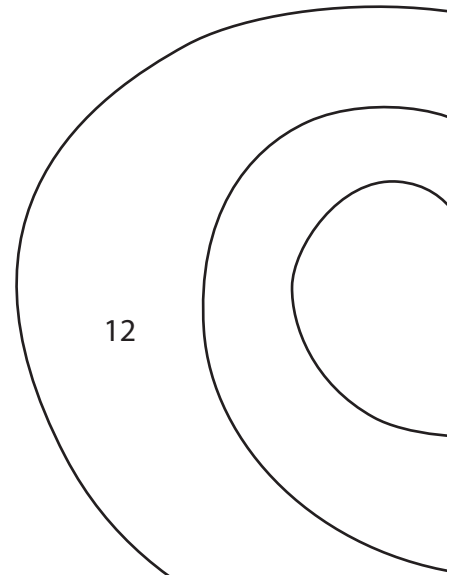
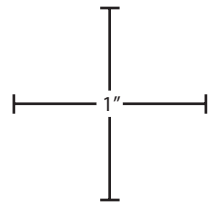
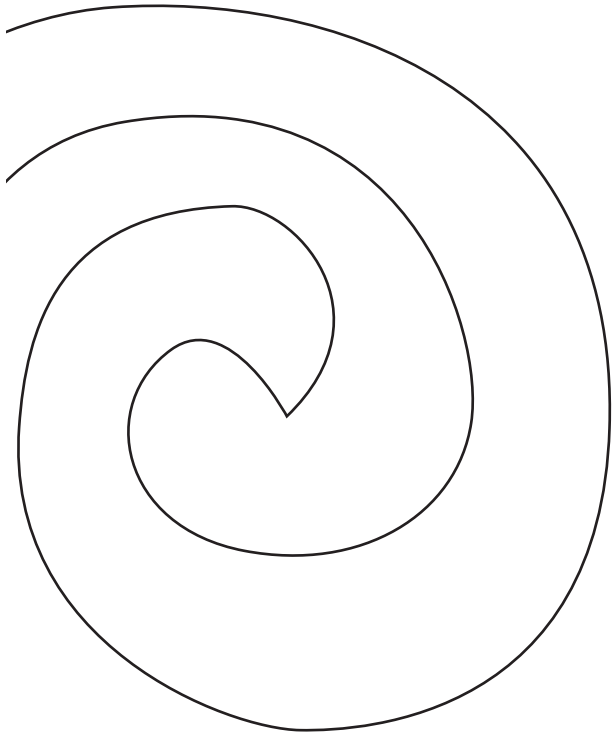

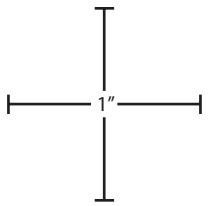
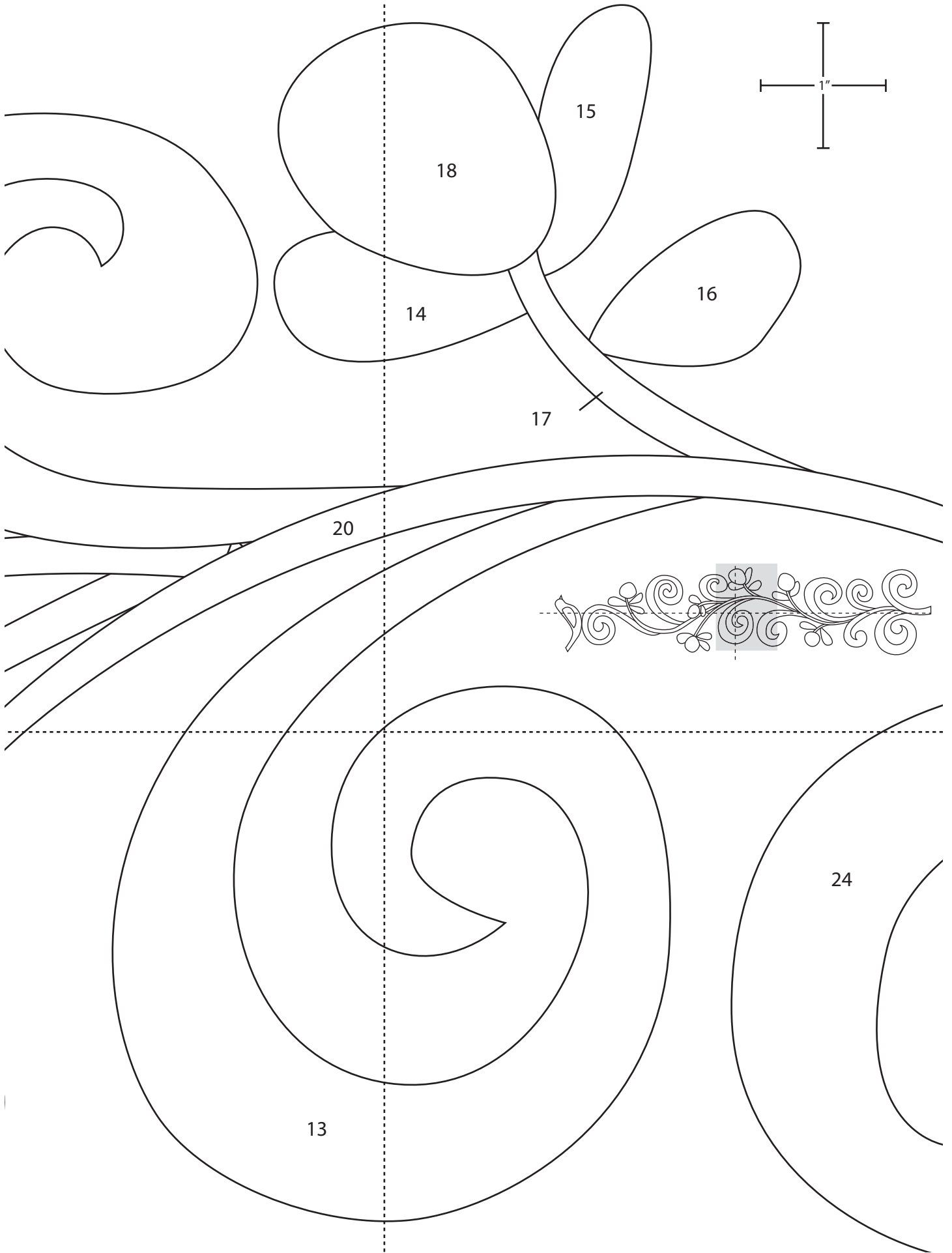

15

18

14

16

17

20

13

24

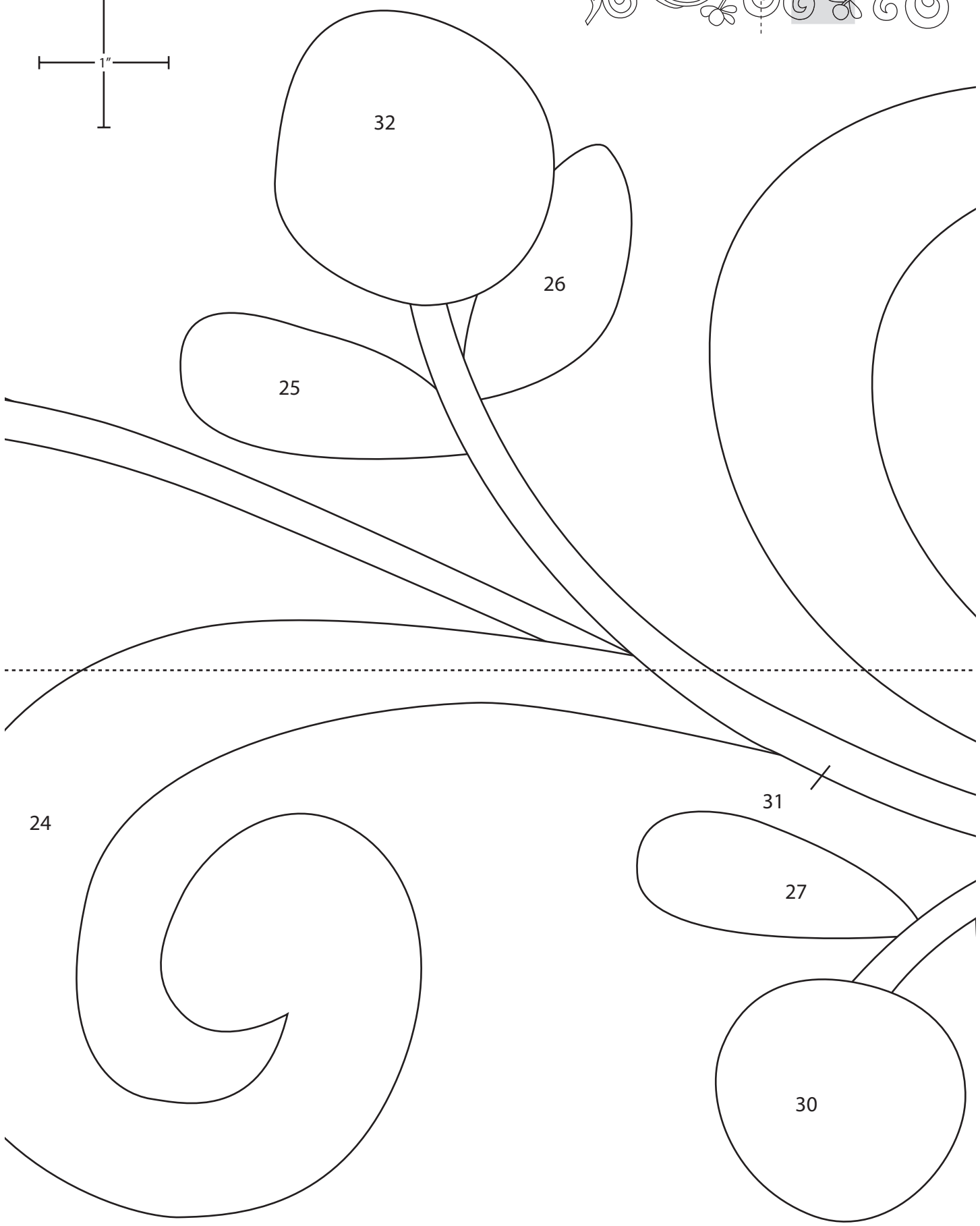
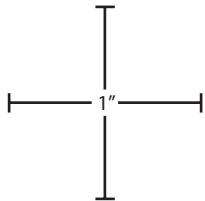
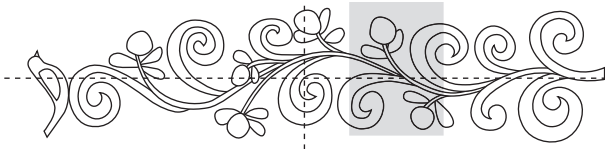

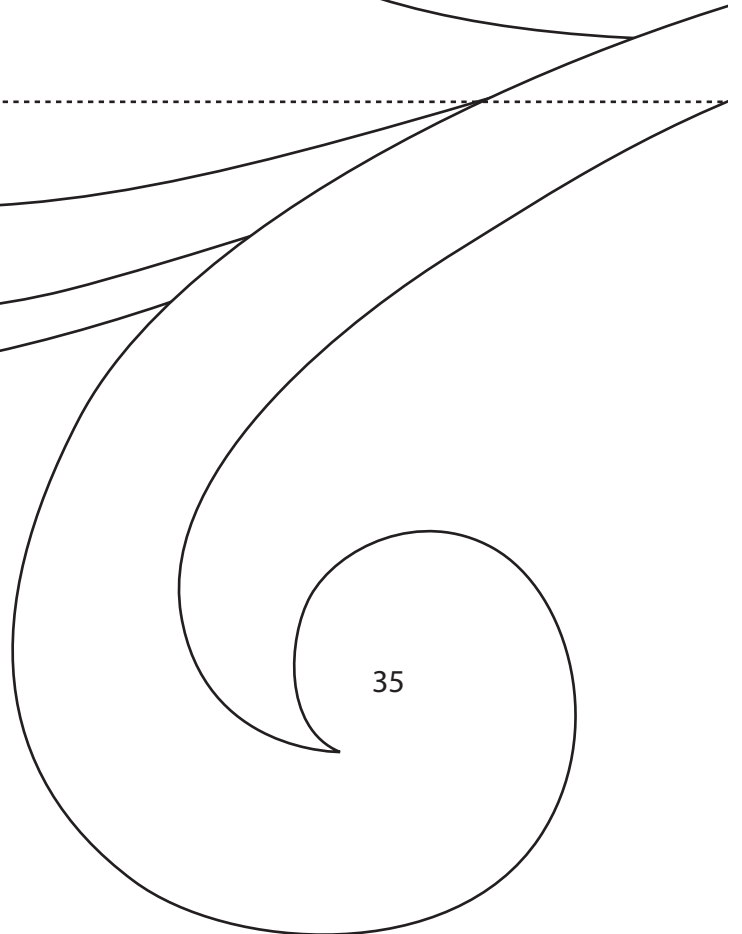
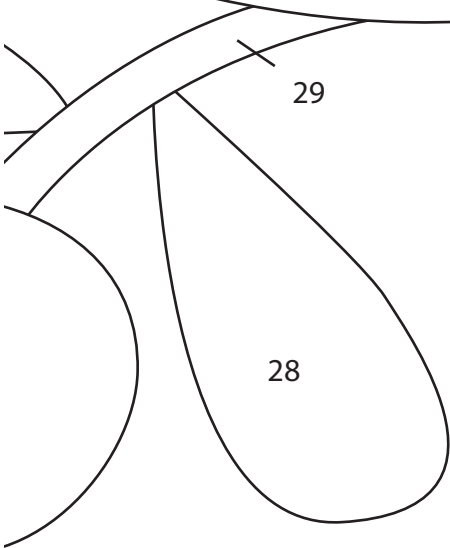
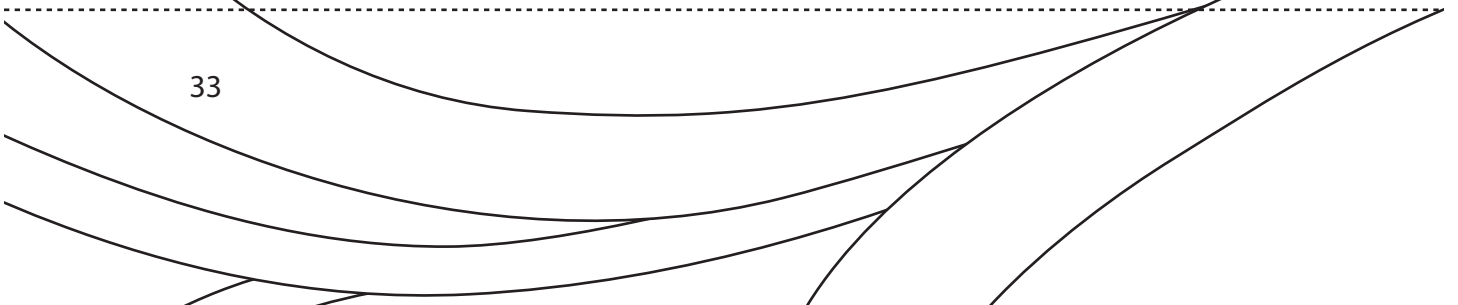
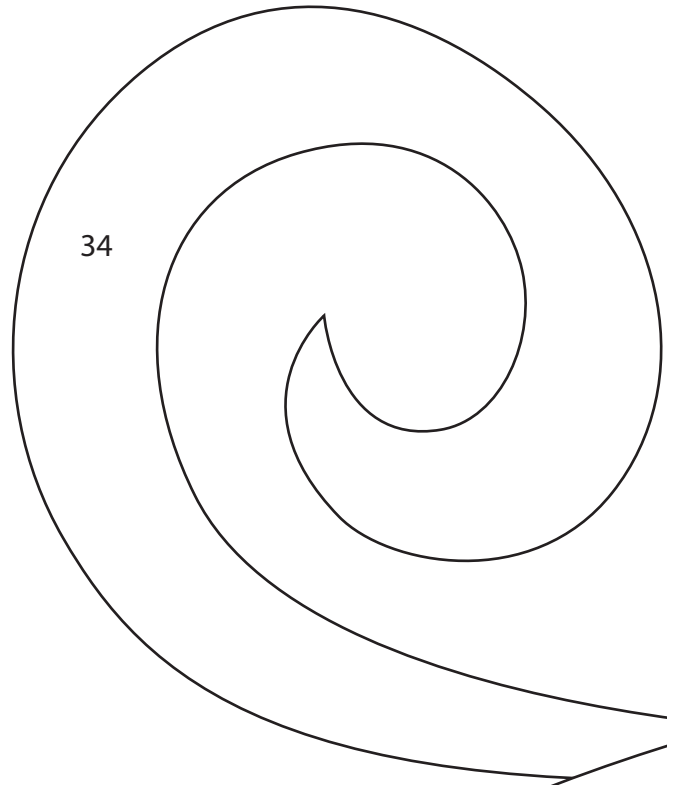
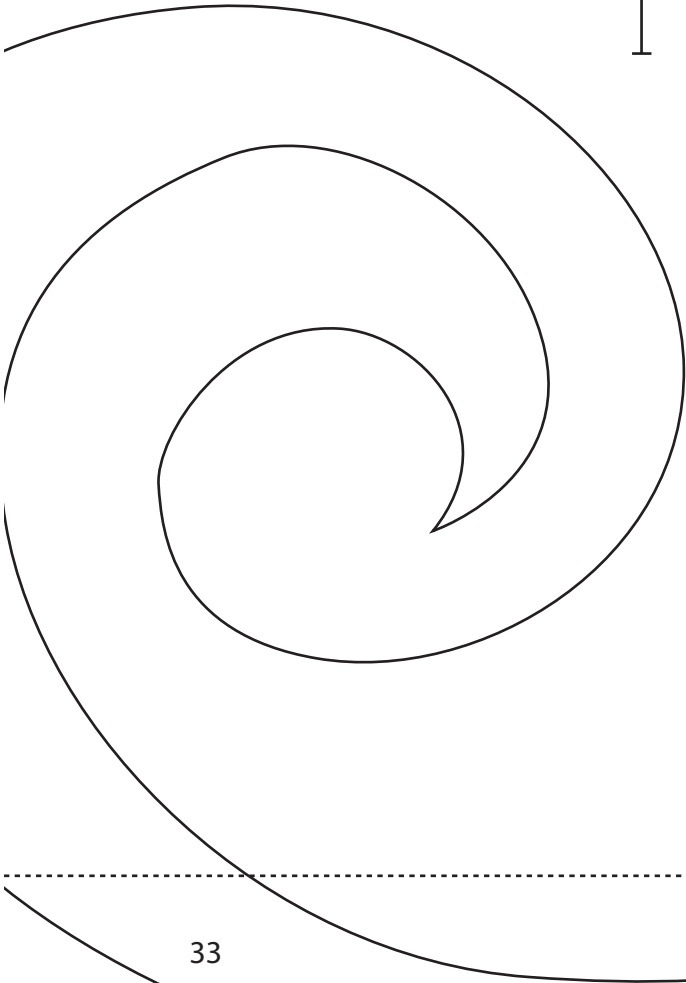
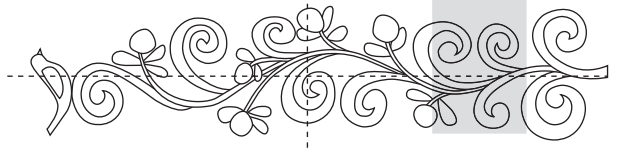
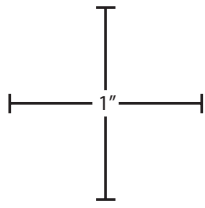

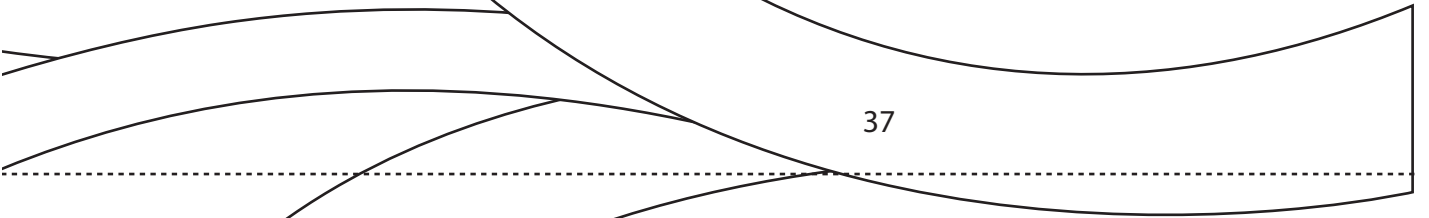
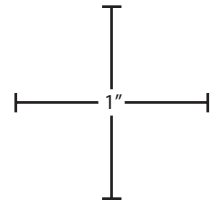
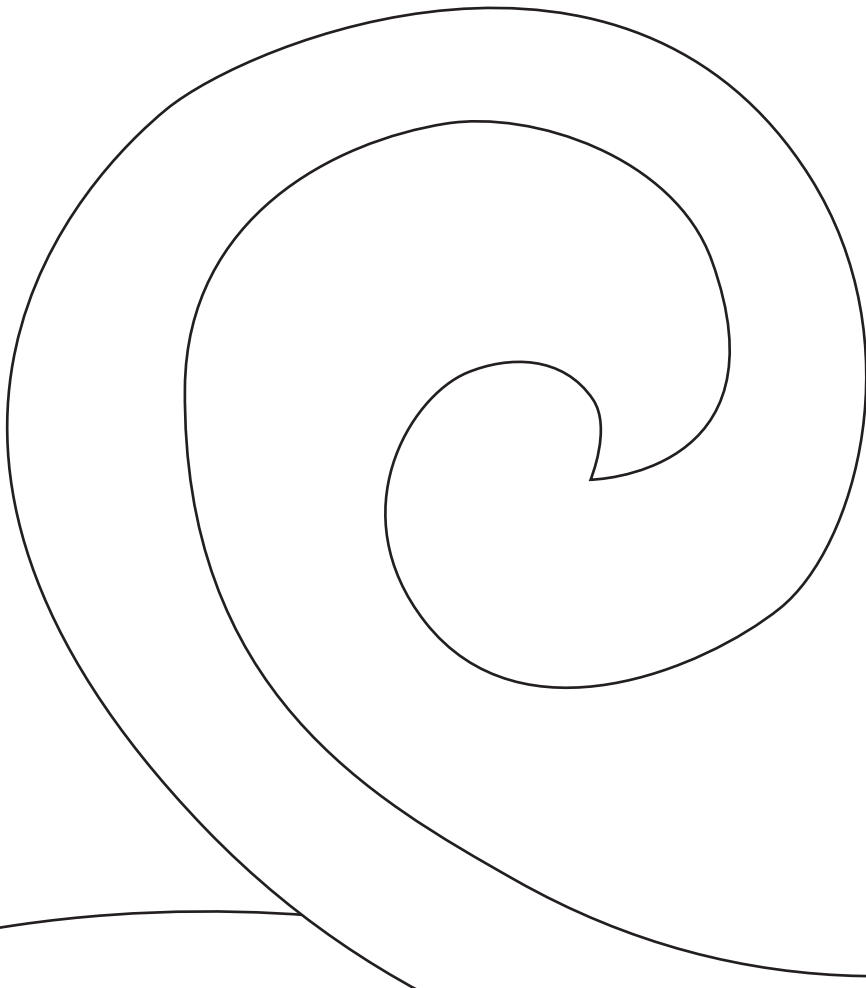
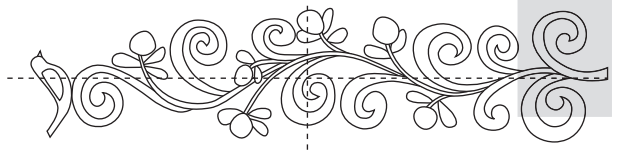

36

37

